

High Precision Ultra-Low TCR
Metal Alloy Current Sensing Resistor

SEWK6398

Resistance **0.1mΩ**

Tolerance **±0.5%**

TCR **±10ppm/°C**

Rated current **200A**

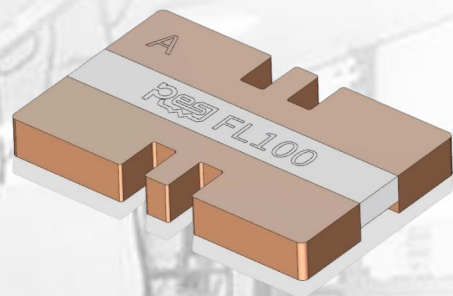

Applicable to

Electric Vehicles | Precision Power Supplies | AI Servers
Lithium-Ion Battery and Semiconductor Test Equipment
Energy Storage | Medical Equipment

Ultra-Low TCR of ± 10 ppm/ $^{\circ}\text{C}$ and Excellent Long-Term Stability

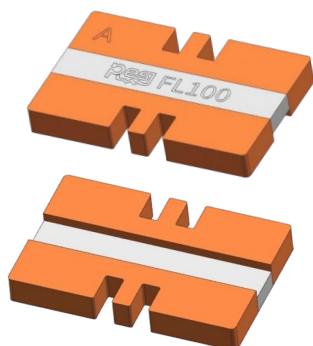

Introduction

This high-precision, ultra-low temperature coefficient metal alloy current-sensing resistor is manufactured using precision resistance alloys developed by C&B. Following precision machining, it is welded using dedicated electron beam welding equipment independently designed and manufactured by the C&B Group. The perfect combination of consistent control over resistance alloy properties, precision machining capabilities, and high-efficiency welding enables the product to achieve a target accuracy of up to $\pm 0.5\%$ after processing. For this series, the temperature coefficient is within ± 10 ppm/ $^{\circ}\text{C}$ across the operating temperature range of $+20^{\circ}\text{C}$ to $+80^{\circ}\text{C}$, with an inductance of ≤ 2 nH.

This series features independent control over raw materials, core equipment, and core processes, ensuring stable quality and on-time delivery. If standard specifications cannot meet your requirements, please contact our sales team for consultation. C&B is committed to providing customers with optimal precision resistor solutions for a wide range of applications, including Electric Vehicles, Precision power supplies, AI Servers, Lithium-Ion battery and Semiconductor test equipment, Energy storage and Medical equipment.

Electrical Parameters

Series	Resistance	Rated Power ($+70^{\circ}\text{C}$)	Max. Operating Current	Operating Temperature	TCR ppm/ $^{\circ}\text{C}$ ($+20^{\circ}\text{C}$ Ref)	Thermal Resistance* $^{\circ}\text{C}/\text{W}$	Tolerance %
SEWK6398	0.1m Ω	4W	200A	$-55^{\circ}\text{C} \sim +170^{\circ}\text{C}$	± 10 ($+20^{\circ}\text{C} \sim +80^{\circ}\text{C}$)	0.86	± 0.5 ± 1.0 ± 5.0

*Internal Thermal Resistance: Internal thermal resistance between the resistive alloy and copper electrode. As power dissipation depends heavily on thermal environment, copper busbar and PCB layout, this parameter is for reference only.

Application

This series of current-sensing resistors features an inductance of ≤ 2 nH and is suitable for AC/DC low- and high-frequency current sensing circuits.

Dimensions

Unit: mm

Resistor

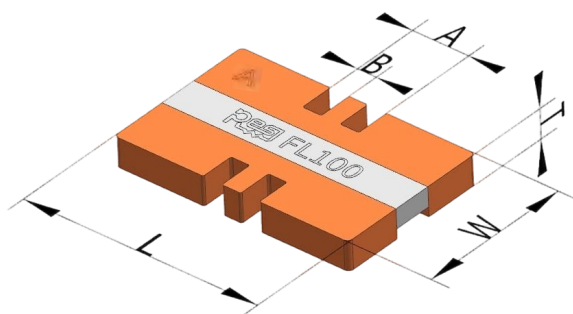

Land Pattern

The current lead-in and lead-out areas must be ≥ 29 mm to provide sufficient buffering for uniform current flow across the resistor. Otherwise, the TCR and accuracy of the resistor will be significantly affected.

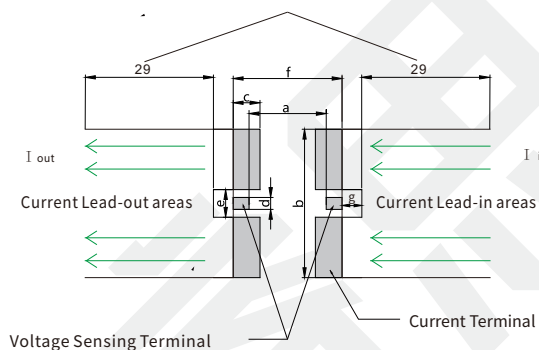

Not following the recommended land pattern design can seriously affect the temperature coefficient measurement results and current sensing accuracy!

Resistance	L	W	T	A	B	a	b	c	d	e	f	g	Quantity per Reel
0.1mΩ	25.0±0.5	16.0±0.5	3.0±0.3	6.0±0.5	2.0±0.3	8.5±0.1	29±0.2	6±0.2	2±0.2	5±0.2	17.5±0.2	2±0.2	600pcs

Part Number Information

Example: SEWK6398FL100N9 (SEWK 6398 ±1.0% 0.1mΩ ±10ppm/°C)

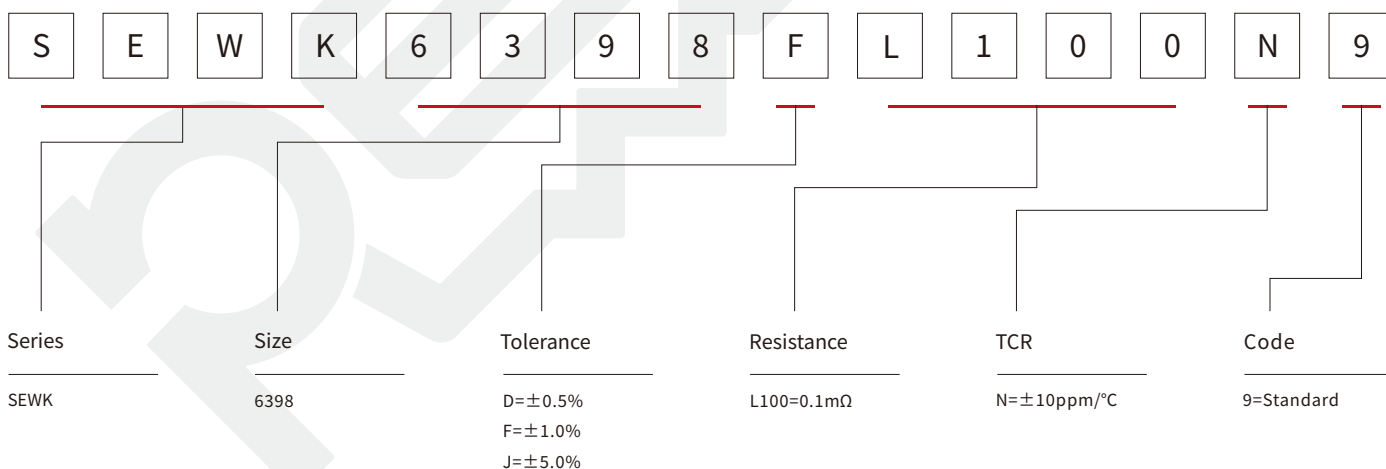

For higher or lower resistance values, higher accuracy, higher power ratings, lower TCR, or larger sizes, please contact us for confirmation.

Performance

Test Item	Test Method	Standards	Typical	Max
High Temperature Storage	1000h @ +170°C, unpowered	AEC-Q200 TEST 3 MIL-STD-202 Method 108	$\Delta R \leq \pm 0.1\%$	$\Delta R \leq \pm 0.3\%$
Thermal Shock	Temperature cycling: -55 °C for 15 min, return to ambient in <20 s, +155 °C for 15 min, 1000 cycles.	MIL-STD-202 Method 107	$\Delta R \leq \pm 0.1\%$	$\Delta R \leq \pm 0.3\%$
Bias Humidity	+85°C, 85% RH, 10% rated power, 1000 hours	AEC-Q200 TEST 7 MIL-STD-202 Method 103	$\Delta R \leq \pm 0.05\%$	$\Delta R \leq \pm 0.2\%$
Load Life	+70°C for 2000h, rated power, 90min on, 30min off +70°C refers to terminal temperature	MIL-STD-202 Method 108	$\Delta R \leq \pm 0.1\%$	$\Delta R \leq \pm 0.3\%$
Mechanical Shock	Half-sine waveform, 100 g peak acceleration, 6 ms pulse duration, 3 shocks in each of 6 directions (X, Y, Z axes, both positive and negative).	AEC-Q200 TEST 13 MIL-STD-202 Method 213	$\Delta R \leq \pm 0.1\%$	$\Delta R \leq \pm 0.2\%$
Vibration	10 Hz – 2 kHz, 5 g, 20 min/cycle, 12 cycles each on X, Y, Z axes.	AEC-Q200 TEST 14 MIL-STD-202 Method 204	$\Delta R \leq \pm 0.1\%$	$\Delta R \leq \pm 0.2\%$
Resistance to Soldering Heat	+260°C heating platform, maintain for 10 seconds	AEC-Q200 TEST 15 MIL-STD-202 Method 210	$\Delta R \leq \pm 0.2\%$	$\Delta R \leq \pm 0.5\%$
Solderability	Solder bath: +245 °C, 10 s	AEC-Q200 TEST 18 IEC 60115-1 4.17	No visible damage Minimum solderable area: 95%	
TCR	Measurement points: +20 °C and +80 °C, reference point: +20 °C	AEC-Q200 TEST 19 IEC 60115-1 4.8	Measured curve . Max. within ± 10 ppm/°C.	
Short Time Overload	5 times rated power, 5 s	IEC 60115-1 4.13	$\Delta R \leq \pm 0.01\%$	$\Delta R \leq \pm 0.2\%$
Low Temperature Storage	-55 °C, 96 h, unpowered	IEC 60068-2-1	$\Delta R \leq \pm 0.1\%$	$\Delta R \leq \pm 0.3\%$

Temperature Coefficient of Resistance Test Curve

TCR Test Curve -SEWK6398 0.1mΩ

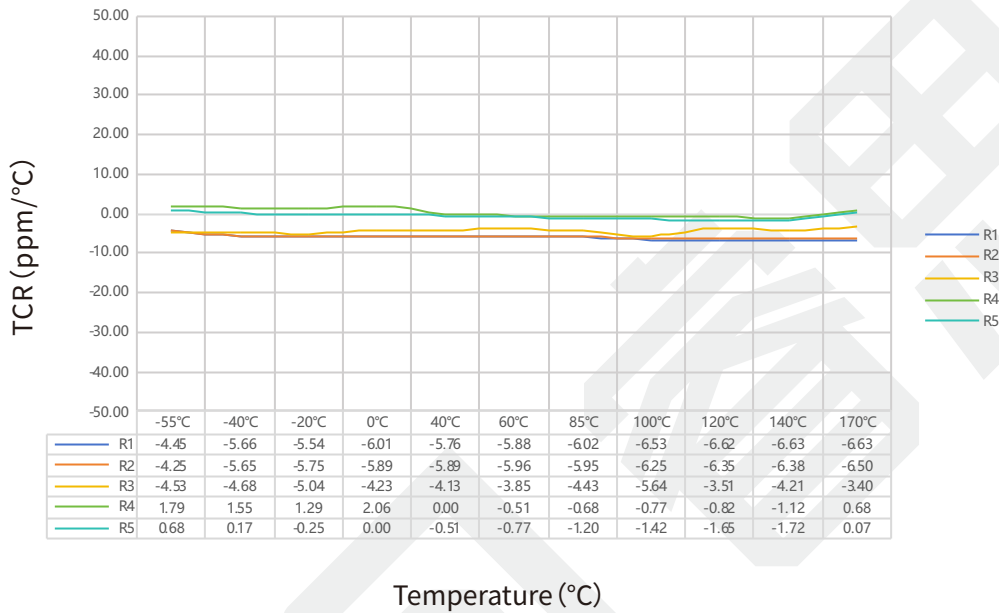

Max Pulse Energy Curve

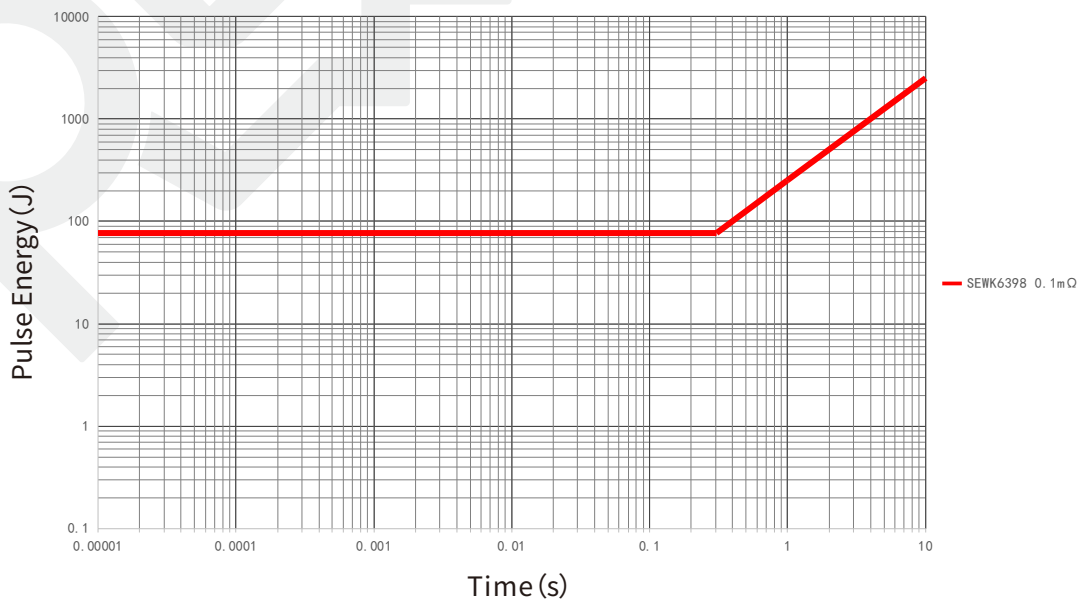

Derating Curve

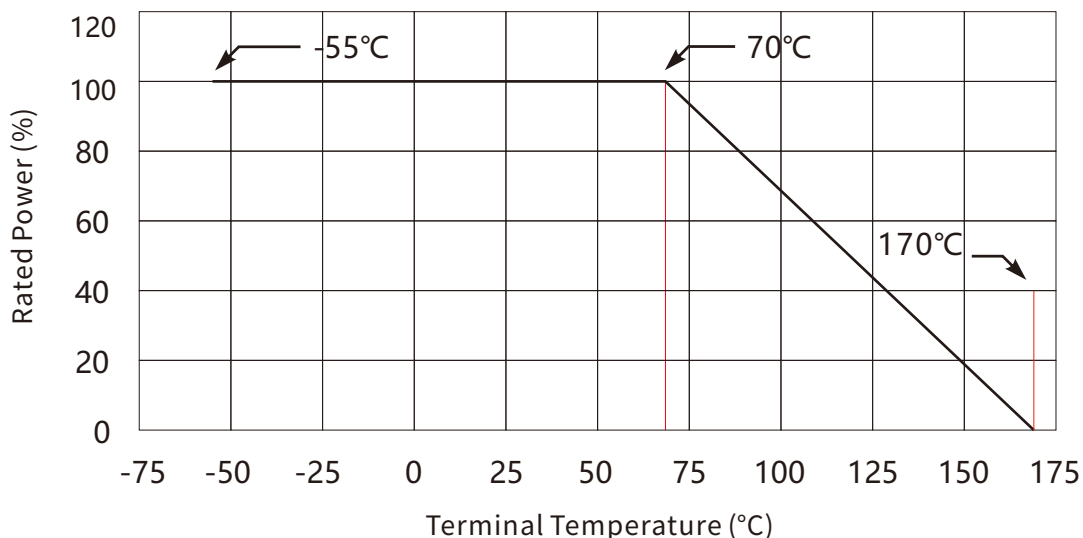

Reflow Soldering Profile

Resistor Surface Temperature:
 Pre-Heat: +150°C~+190°C, 60~120sec.
 Reflow: +220°C and above, 90~150sec.
 Applicable Solder Composition:
 Sn-Ag-Cu solder.

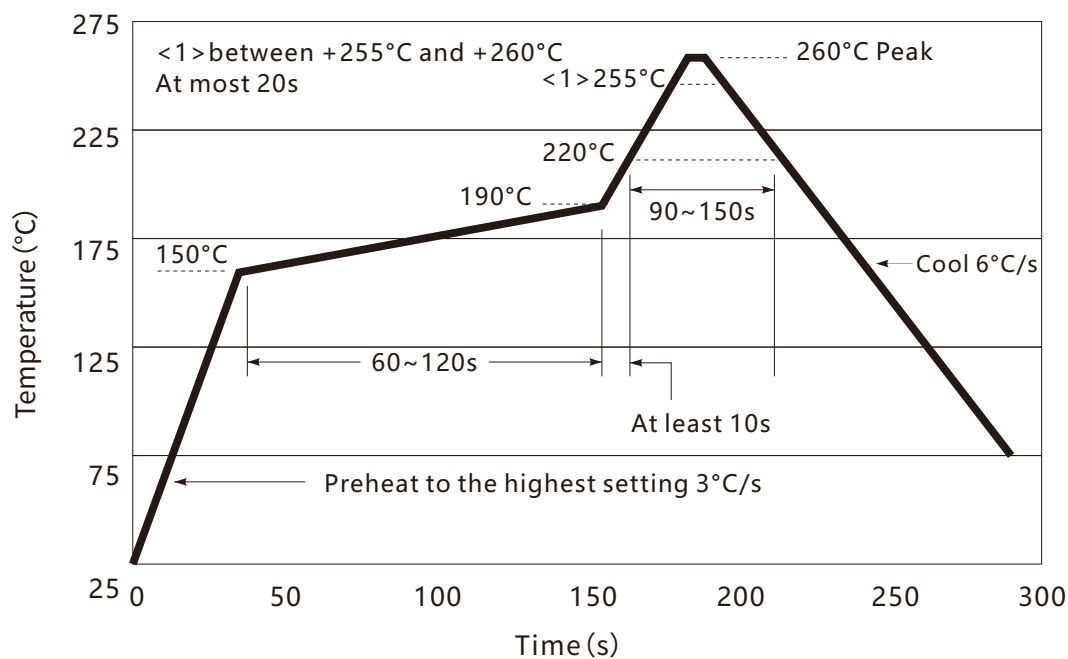

Construction

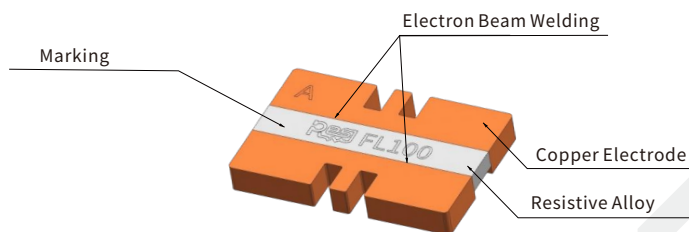

Marking

The product marking consists of: logo + tolerance code + resistance code.

Size

Illustration

Demonstration

6398



RESI: LOGO
 A: TCR 10ppm/°C
 F: Tolerance
 L100: Resistance

Storage Instructions

- (1) Resistors shall be stored at a temperature of 5 to 35 °C and a humidity of < 60% RH, and humidity should be kept as low as possible.
- (2) Resistors should be kept away from direct sunlight.
- (3) Resistors should be stored in a clean and dry environment free of harmful gases (HCl, sulfur-containing gases, H₂S, etc.).
- (4) Do not remove the resistor from its packaging until ready for use.
- (5) Under the storage conditions described above, the resistor can be stored for at least 1 year.

Usage Suggestions

- (1) During handling, take care to protect the surface of the product to avoid defects such as scratches, nicks, or contamination, such as oil stains.
- (2) Do not use sharp tweezers to pick up or place the product. Surface scratches may cause resistance shift or failure.
- (3) During installation, avoid exposing the product to mechanical stress.
- (4) The continuous operating power applied to the resistor should be less than or equal to its rated power to prevent resistance drift caused by long-term overload.
- (5) When using the resistor in high-temperature environment or under poor heat dissipation conditions, refer to the power derating curve and ensure the power is derated accordingly.
- (6) If the operating conditions exceed the pulse load specified in the pulse curve, system-level evaluation and validation are required.
- (7) If resistors are removed from the tape and reel packaging but not used immediately, they should be stored under vacuum to prevent oxidation, which may lead to soldering issues.

Packaging

Tape Specifications

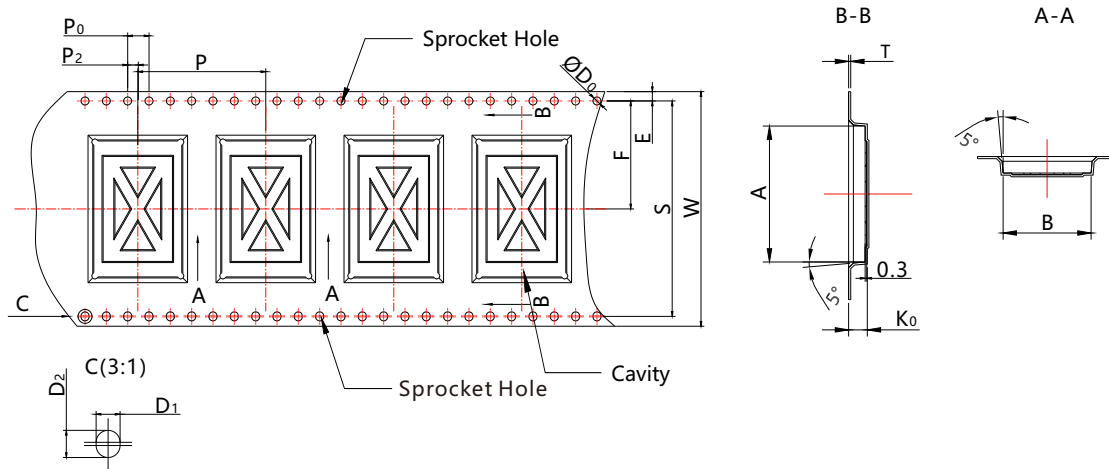

Resistance	A	B	K ₀	φD ₀	φD ₁	φD ₂	P	P ₀	P ₂	E	F	S	W	T
0.1mΩ	25.5±0.1	16.5±0.1	3.5±0.1	1.5±0.1	1.5±0.1	1.7±0.1	24.0±0.1	4.0±0.1	2.0±0.1	1.75±0.1	20.2±0.1	40.4±0.1	44±0.3	0.4±0.05

Reel Specifications

Unit:mm

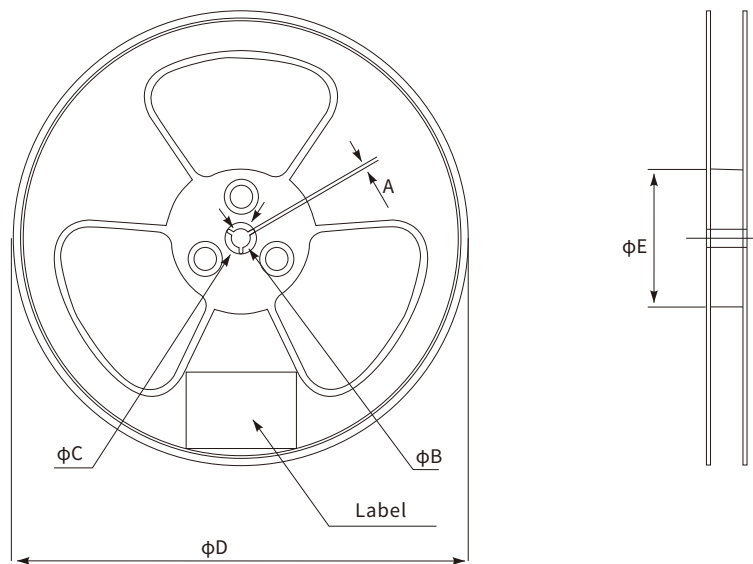

A	φB	φC	φD	φE
1.5 min.	13.5 +0.5/-0.2	20.2 Min.	300±2	100±2

Packaging

- (1) 600 pcs of resistors are taped onto a plastic reel.
- (2) Each plastic reel is secured with a cardboard tray, approximately 335 mm × 340 mm × 52 mm in size.
- (3) Two cardboard trays are placed into one outer carton, i.e., 1,200 pcs per carton as standard packaging.
- (4) The standard outer carton dimensions are approximately 350 mm × 370 mm × 165 mm.
- (5) Sample orders are packed in cardboard boxes.

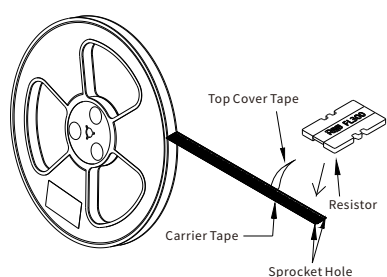

1. 600 pcs of resistors are taped onto a plastic reel.

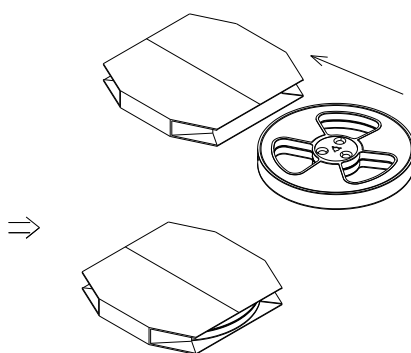

2. Each plastic reel is secured with a cardboard tray. The tray dimensions are approximately 335mm*340mm*52mm.

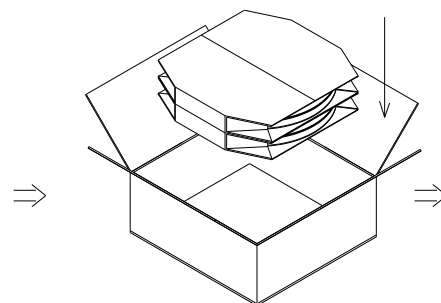

3. Two cardboard trays are placed into one outer carton; that is, each carton contains two reels as standard packaging.

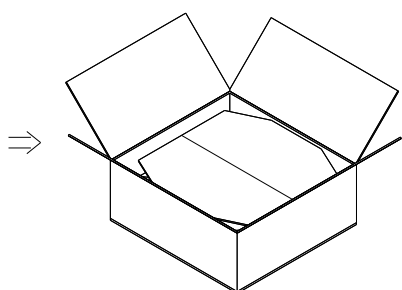

4. Bubble film or pearl cotton shall be used as filling material on both sides of the cardboard divider to prevent the products from shifting inside the carton.

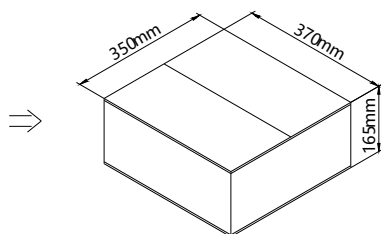





















5. Outer carton dimensions: 350 mm × 370 mm × 165 mm.











Popular Part Numbers

Part Number	Size	Tolerance	Resistance	TCR	Rated Power	Max. Operating Current
SEWK6398DL100N9	6398	±0.5%	0.1mΩ	±10ppm/°C	4W	200A
SEWK6398FL100N9	6398	±1.0%	0.1mΩ	±10ppm/°C	4W	200A
SEWK6398JL100N9	6398	±5.0%	0.1mΩ	±10ppm/°C	4W	200A

Broad Portfolio of Current Sensing Resistors

Series	Product	Rated Power +70°C	Resistance Range	Tightest Tolerance	Best TCR
PCSR2512		1W~2W	5mΩ~200mΩ	±0.1%	±10ppm/°C
PCSR3637		2W~5W	1mΩ~200mΩ	±0.1%	±15ppm/°C
PCSK2512		1W~2W	5mΩ~200mΩ	±0.5%	±25ppm/°C
PCSK3637		2W~5W	1mΩ~200mΩ	±0.5%	±25ppm/°C
MCSM2512		3W	0.5mΩ~2mΩ	±0.5%	±100ppm/°C
MCSF2512		2W~3W	3mΩ~100mΩ	±0.5%	±50ppm/°C
PEWM1206		6W	0mΩ~1mΩ	±1.0%	±100ppm/°C
PEWM1216		3W~10W	0.1mΩ~0.2mΩ	±1.0%	±50ppm/°C
PEWK1216		3W~10W	0.3mΩ~3mΩ	±1.0%	±50ppm/°C
PEWM2512		6W	0.5mΩ~1mΩ	±0.5%	±100ppm/°C
SEWK2512		4W~5W	1mΩ~3mΩ	±0.5%	±10ppm/°C
EBWM2512		6W	0mΩ~1mΩ	±0.5%	±200ppm/°C
EBWK2512		2.5W~5W	2mΩ~5mΩ	±0.5%	±100ppm/°C
SEWF2512		2.5W~4W	3mΩ~5mΩ	±0.5%	±25ppm/°C
PEWF2512		2.5W~5W	1.5mΩ~5mΩ	±0.5%	±50ppm/°C
PEWM3920		8W~12W	0.1mΩ~1mΩ	±0.5%	±100ppm/°C
PEWK3920		3W~8W	1mΩ~5mΩ	±0.5%	±50ppm/°C
SEWF3920		3W~8W	1mΩ~5mΩ	±0.5%	±25ppm/°C
SEWK3920		5W~8W	1mΩ~3mΩ	±0.5%	±10ppm/°C
SEWM3920		8W~12W	0.2mΩ~1mΩ	±0.5%	±50ppm/°C

Broad Portfolio of Current Sensing Resistors

Series	Product	Rated Power +70°C	Resistance Range	Tightest Tolerance	Best TCR
SEWK3951		15W	0.25mΩ~0.4mΩ	±0.5%	±25ppm/°C
SEWF3951		10W~15W	0.3mΩ~0.8mΩ	±0.5%	±25ppm/°C
SEWF5930		6W~10W	1mΩ~3mΩ	±0.5%	±25ppm/°C
PEWM5930		9W~15W	0.1mΩ~1mΩ	±0.5%	±100ppm/°C
PEWK5930		10W	1mΩ	±0.5%	±50ppm/°C
SEWM5930		9W~15W	0.2mΩ~1mΩ	±0.5%	±50ppm/°C
PEWF4026		3W~7W	1mΩ~5mΩ	±0.5%	±50ppm/°C
PEWF2726		3W~7W	1mΩ~5mΩ	±0.5%	±50ppm/°C
PEWM4026		7W~12W	0.2mΩ~1mΩ	±0.5%	±75ppm/°C
PEWM2726		7W~12W	0.2mΩ~1mΩ	±0.5%	±75ppm/°C
SEWK6398		4W	0.1mΩ	±1.0%	±10ppm/°C

Revision

Version	Revised Content	Date	Approver
V0	Initial Issue	2026.03.11	LWW
V1	Added marking	2026.03.30	LWW

Disclaimer

All products, datasheets and data can be changed without prior notice.

C&B Electronics Shenzhen CO., LTD., its affiliates, distributors, employees, and any other person acting on its behalf (collectively referred to as "C&B Electronics") shall not bear any legal responsibility for any errors, inaccuracies, or incompleteness of information related to the product disclosed under this agreement or other disclosures.

Product datasheet does not constitute an extension or revision of the purchase terms and conditions in C&B Electronics, including but not limited to the warranties under this agreement.

Unless specified in the purchase terms and conditions, C&B Electronics makes no guarantees, representations or warranties.

To the maximum extent permitted by applicable laws, C&B Electronics hereby makes the following disclaimer:

- (1) All liabilities arising from the use of the product;**
- (2) Including but not limited to all liabilities arising from special, indirect or incidental damages;**
- (3) All implied warranties, including warranties of suitability for special purposes, non infringement possibility, and marketability.**

The information provided in the datasheet and parameter tables may vary in different applications, and the performance of the product may change over time. The recommended application instructions for the product are based on C&B Electronics' understanding and experience of typical requirements. Customers are obligated to verify whether the product is suitable for a specific application based on the parameters provided in the datasheet. Before officially installing or using the product, you should ensure that you have obtained the latest version of relevant information, which can be obtained through the website: resistor.today.

The signing of this agreement does not constitute an express, implied or other form of license related to all intellectual property rights of C&B Electronic Products.

Unless explicitly stated, the products listed in this agreement are not applicable to lifesaving or life sustaining products. In the absence of a clear indication, the customer shall bear all risks caused by unauthorized use of the above products and agree to fully compensate C&B Electronics for all losses caused by such sales or use. For written product terms for such special applications, please contact authorized personnel from C&B Electronics to obtain.

The names and markings on the listed products may be trademarks owned by others.